

A battery powered, magnetic travel carriage for welding in the vertical or horizontal position.

BUG-GY-VERT III

Increase welding production, improve weld quality and eliminate operator fatigue.



Bug-O Systems

Automated Cutting and
Welding Systems.

1-412-331-1776
www.bugo.com





BUG-GY-VERT III

The BUG-GY-VERT III is a portable battery powered 4-wheel drive welding carriage with or without torch oscillation. Strong permanent magnets hold the machine on the workpiece allowing it to travel on vertical or oblique work surfaces. Guide wheels on the BUG-GY-VERT III automatically track the torch in the fillet joint.

The BUG-GY-VERT III is compact, lightweight and easy to position. It will accommodate most hand held welding guns. By providing consistent travel speed the BUG-GY-VERT III can increase the productivity and the quality of welding applications in many areas of steel fabrication or shipbuilding.



BUG-GY-VERT III Without Oscillation

VFW-3350 110 volt - includes 1 battery and 1 charger.
 VFW-3352 220 volt - includes 1 battery and 1 charger.



BUG-GY-VERT III With Oscillation

VFW-3300 110 volt - includes 1 battery and 1 charger.
 VFW-3302 220 volt - includes 1 battery and 1 charger.

BUG-GY-VERT III Controls With Oscillator.

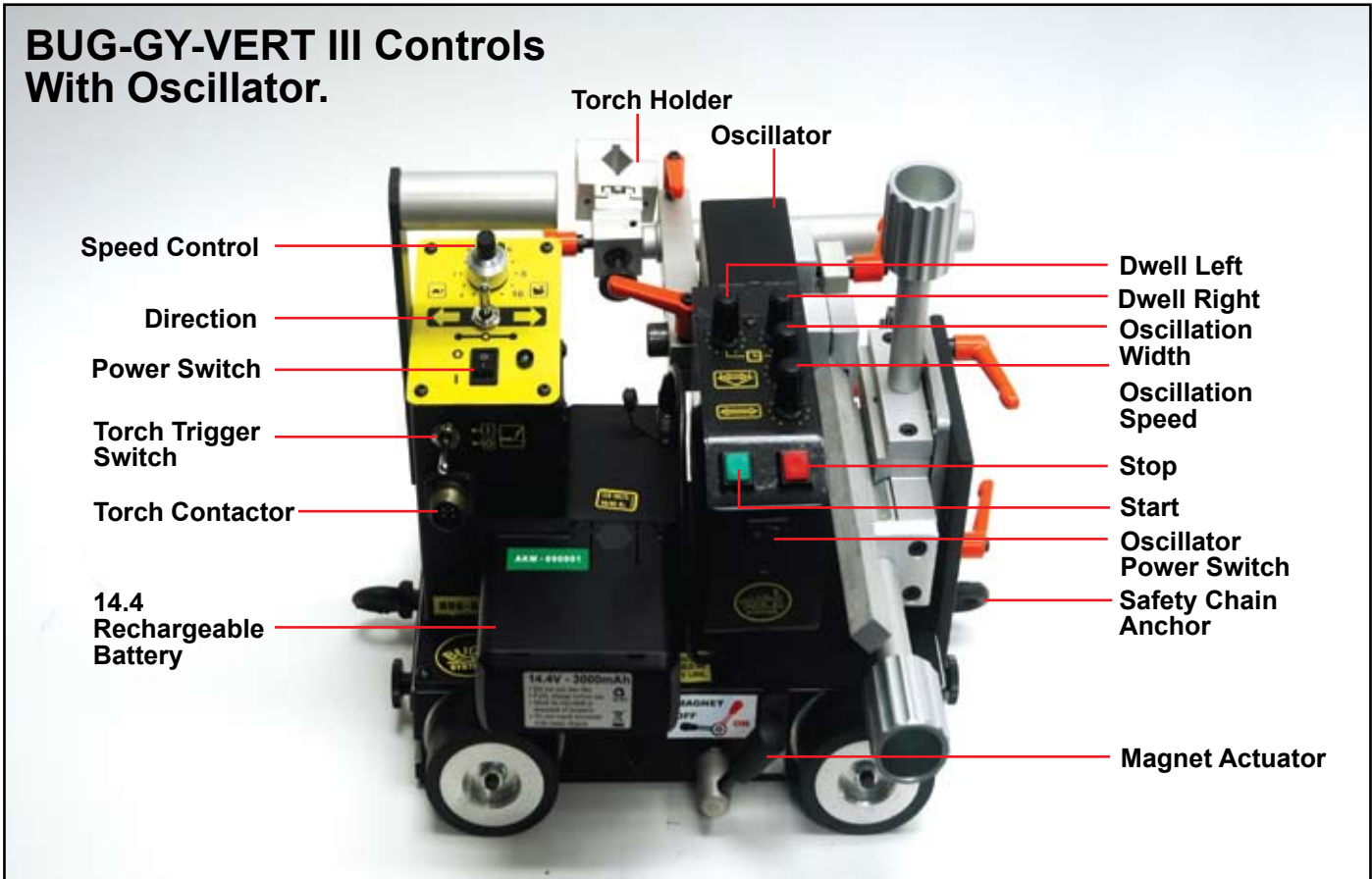



BUG-GY-VERT III

Technical Data:

Power Supply:	14.4V (2Ah-rechargeable battery)	Shipping Weight without Oscillator:	37 lbs. (17 kg.)
Position of Weld:	Vertical & Horizontal	Shipping Weight with Oscillator:	43 lbs. (20 kg.)
Dimensions:	See page 4	Travel Speed:	2.5-50 ipm (60-1250 mm/min)
Carriage to Work Clearance:	.25" (6.5 mm)	Oscillation Width (amplitude):	0-.75" (0-19 mm)
Minimum Plate Thickness:	3/16" (5 mm)	Oscillation Frequency:	20-60 cycles/min.
Wheel Movement:	4 wheel drive	Dwell-Independent Each Side:	0-1.5 seconds

Vertical carrying capacity varies with material thickness. On 3/8" (9.5 mm) plate, carrying capacity is 20 lbs (9.1 kg).

NOTE: Surface must be clean and unpainted. Cables should be supported independently.

Caution: Always use safety cable when working in the vertical position. Fall arrestor safety cables available. Contact the factory for additional details.

Accessories:



H01134-001-01-02
14.4 volt rechargeable battery.



H01113-001-01-03 110 volt battery charger.
H01113-001-01-02 220 volt battery charger.

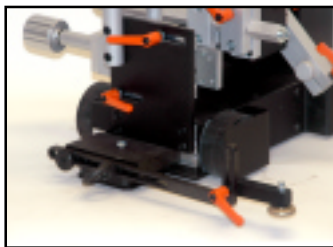

VFW-3210
Auxiliary Magnets
For increased magnetic holding power and traction.

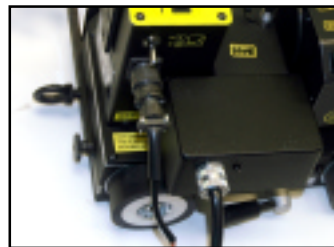

BMV-1510 110 volt Adaptor
BMV-1512 220 volt Adaptor
Power Adaptors - converts machine from battery power to 110 volt or 220 volt line power.



BUG-GY-VERT III

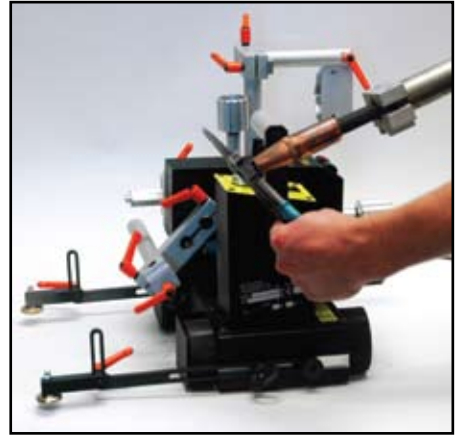

The BUG-GY-VERT III features "Torch Quick Connect" which allows the operator to easily remove or install the torch from the BUG-GY-VERT III for quick nozzle cleaning, wire cutting and hand welding.

Dimensions:

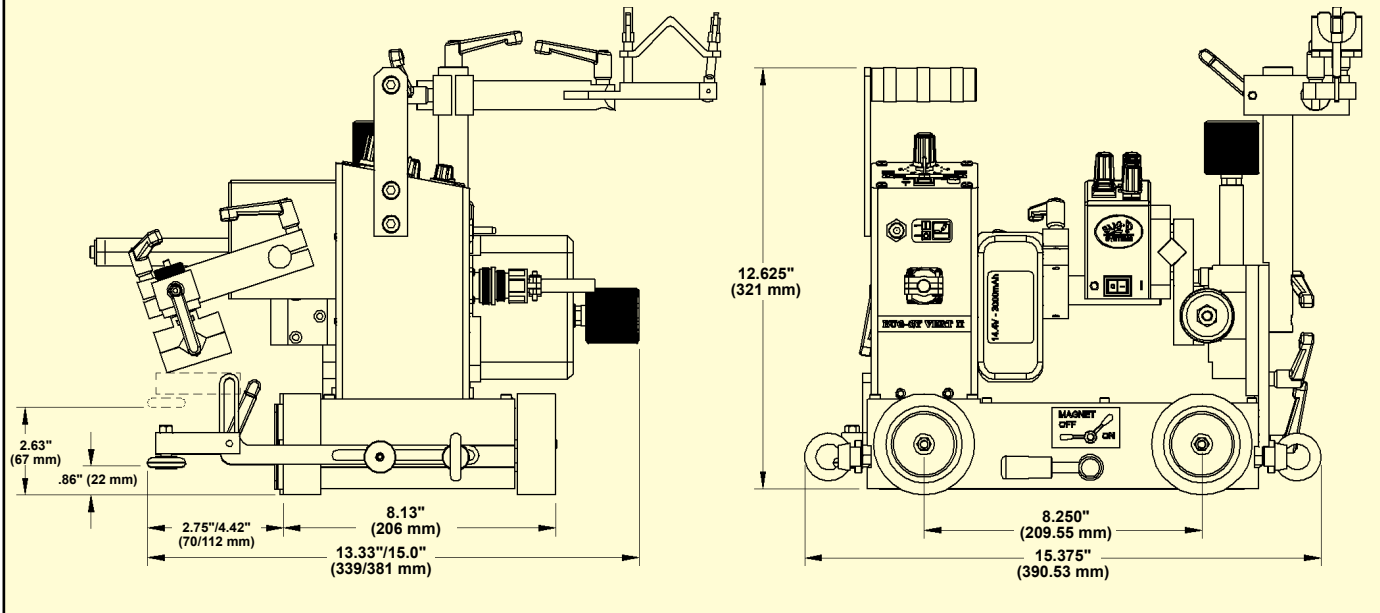

Each unit will be delivered with one (1) battery and charger.



Welding and Cutting Solutions Since 1948.

Bug-O Systems

Visit us online at: www.bug-o.com

A QUALITY PRODUCT FROM BUG-O SYSTEMS • 280 TECHNOLOGY DRIVE • CANONSBURG, PA 15317-9564 USA
A DIVISION OF WELD TOOLING CORPORATION © Weld Tooling Corp. ΧΡΙΣΤΟΣ ROM 1:16 Litho in U.S.A.

LIT-BUG-GY-VERT-BRO-0709